

# Co-continuous degradable composites for medical applications

A red circular logo with a white center, containing a blue horizontal bar with the text 'MIND THE GAP' in white capital letters.

**MIND THE GAP**

Lisa M. Ehrenfried

# Aim: Material for bone repair and bone filling

Examples: Tumor removal

Hip implant revision surgery

Solutions: • Bone Grafts

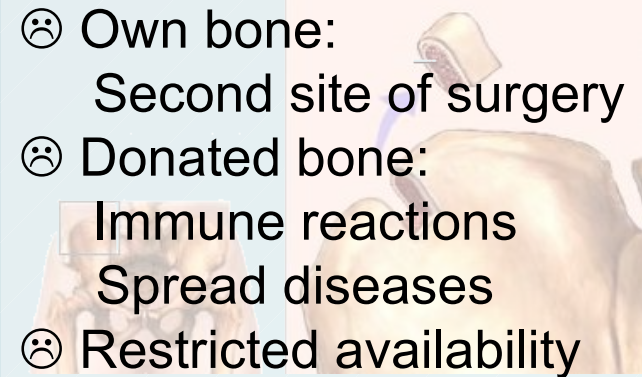
- 
- ☹ Own bone:  
Second site of surgery
  - ☹ Donated bone:  
Immune reactions  
Spread diseases
  - ☹ Restricted availability



# Aim: Material for bone repair and bone filling

Examples: Tumor removal  
Hip implant revision surgery

Solutions: • Bone Grafts  
• Non-resorbable,  
man-made materials

- ☺ Always available
- ☺ Good for patients with slow bone growth/osteoporosis

# Aim: Material for bone repair and bone filling

Examples: Tumor removal

Hip implant revision surgery

Solutions: • Bone Grafts

• Non-resorbable, man-made materials

• Resorbable

Materials that will be replaced by bone



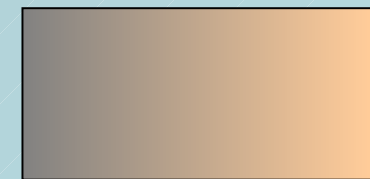
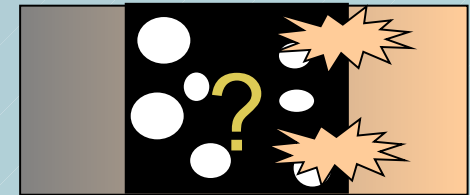
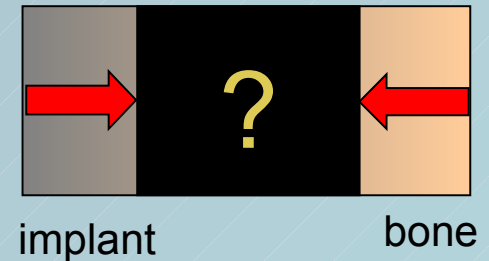

# The ideal resorbable Material

- Initially mechanically stable
- Offers porous structure optimized for bone ingrowth
- Eventually dissolved and completely replaced by bone.

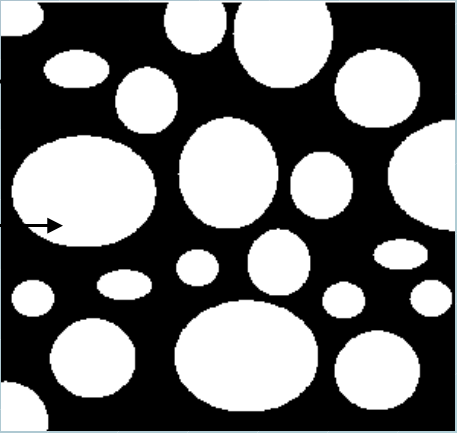

Tight bond between implant and bone

# Degradable co-continuous Composites

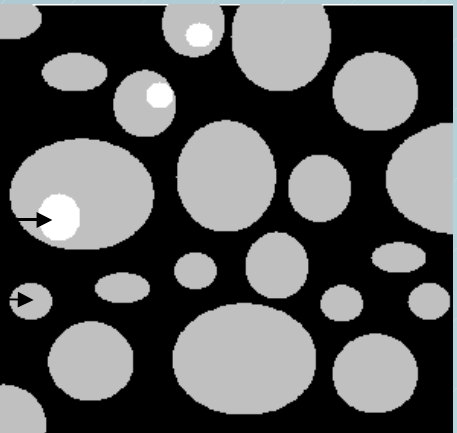
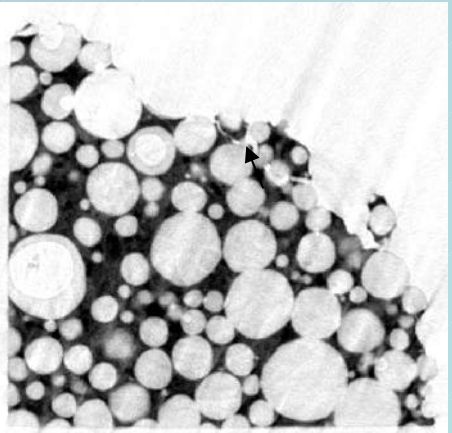
	Schematic	Real (X-ray tomography)
<p>Porous <u>C</u>alcium-<u>P</u>hosphate Matrix (CP)</p> <p>pore size: 500<math>\mu</math>m porosity: 82%</p> <p><math>\beta</math>-Tricalcium Phosphat (<math>\beta</math>-TCP) or Hydroxylapatite (HA)</p>		
<p>Porous Matrix filled with degradable Polymer</p> <p>(Poly (D,L) lactide, PDLLA)</p>		

# Experiments to study degradation and mechanical properties

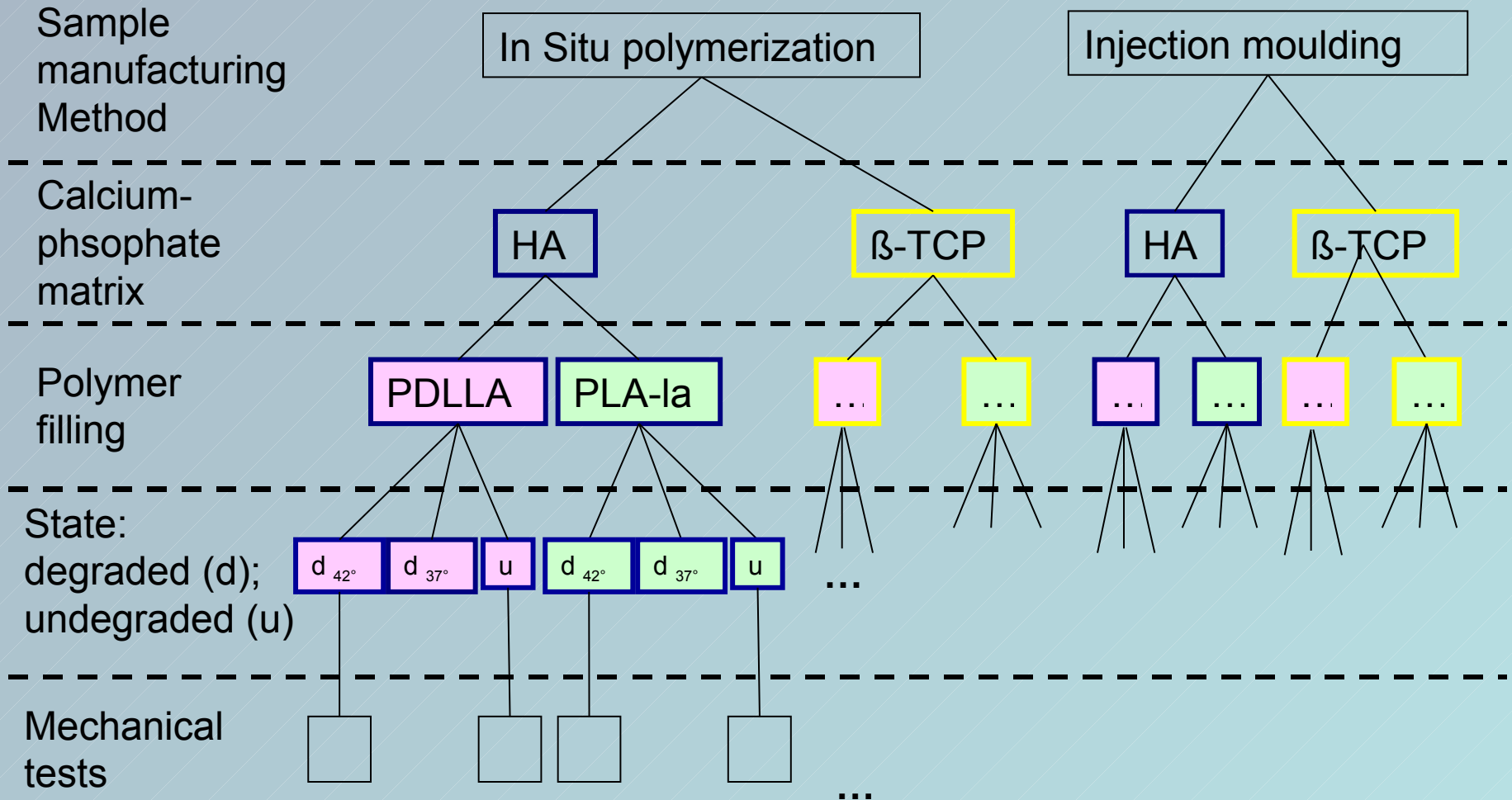

Thank you!

Questions?

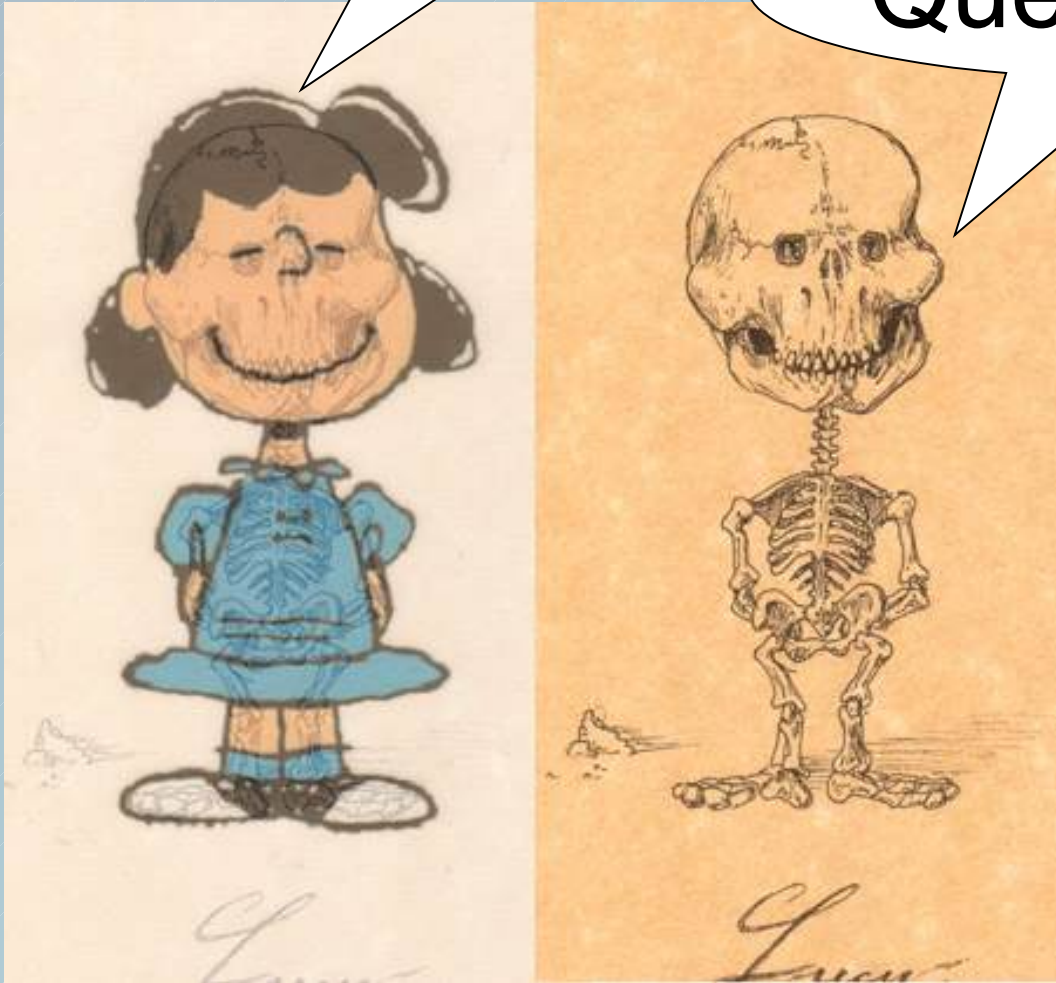

# Sample manufacture

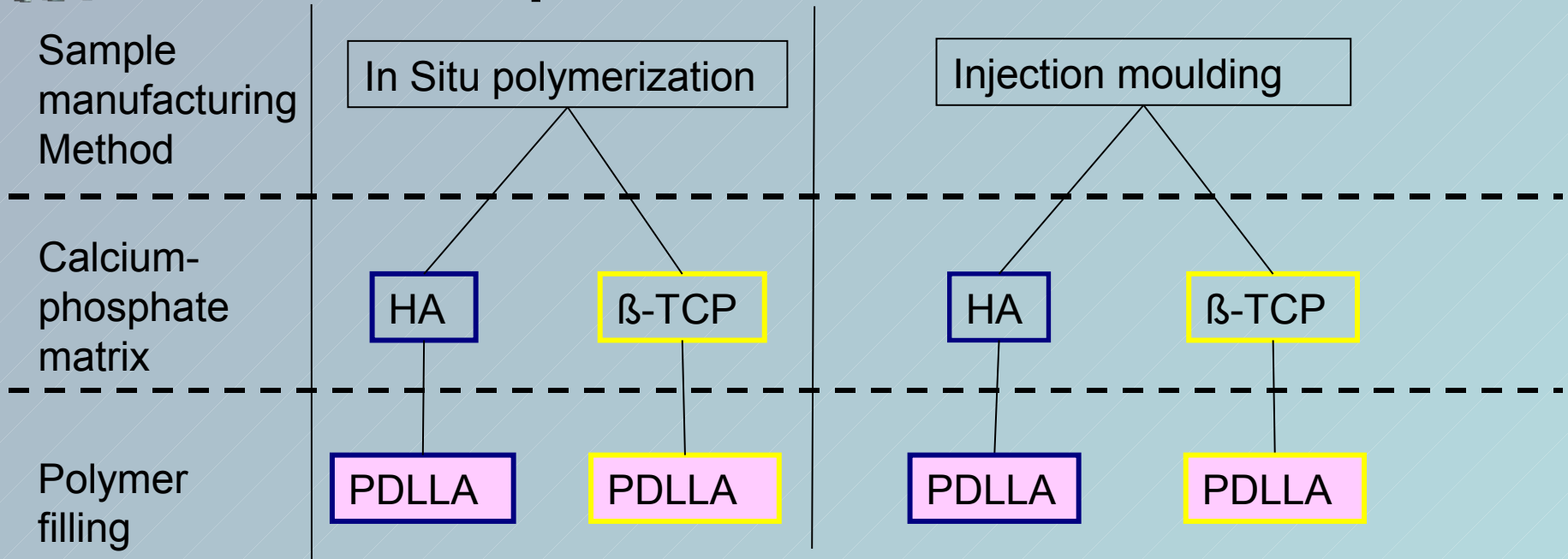

# Sample manufacture

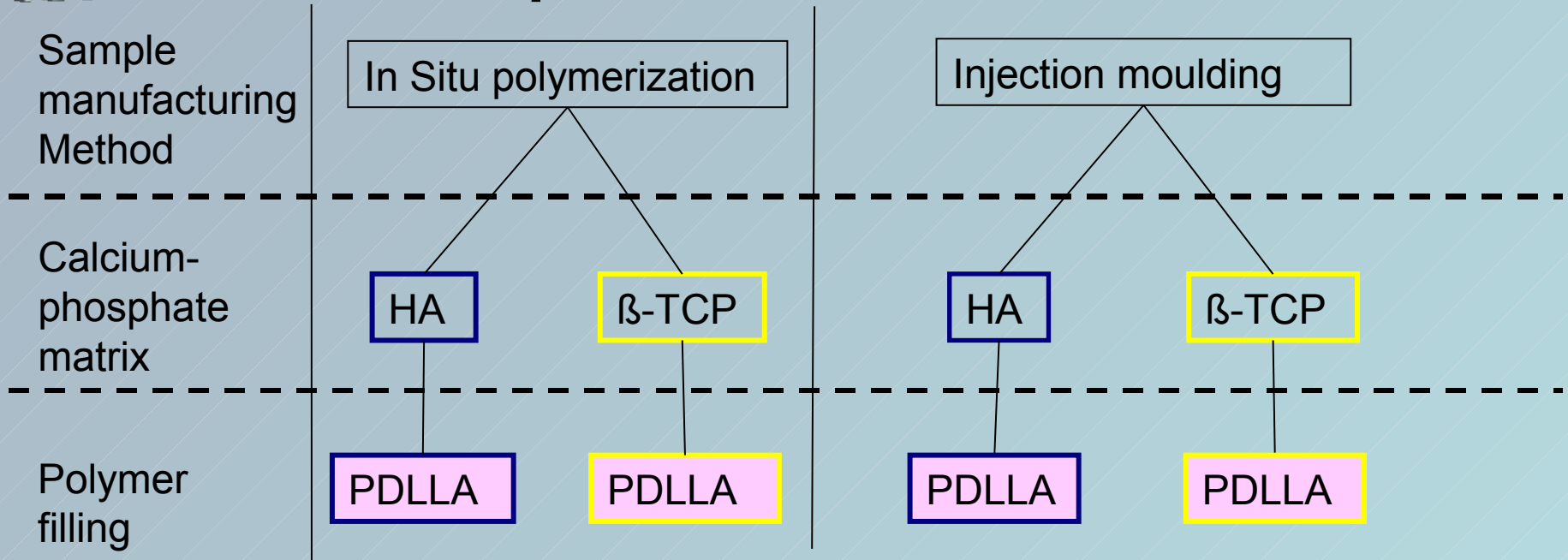

- ☺ No major machines required
- ☹ Not for large scale production
- ☹ Low initial molecular weight

# Sample manufacture

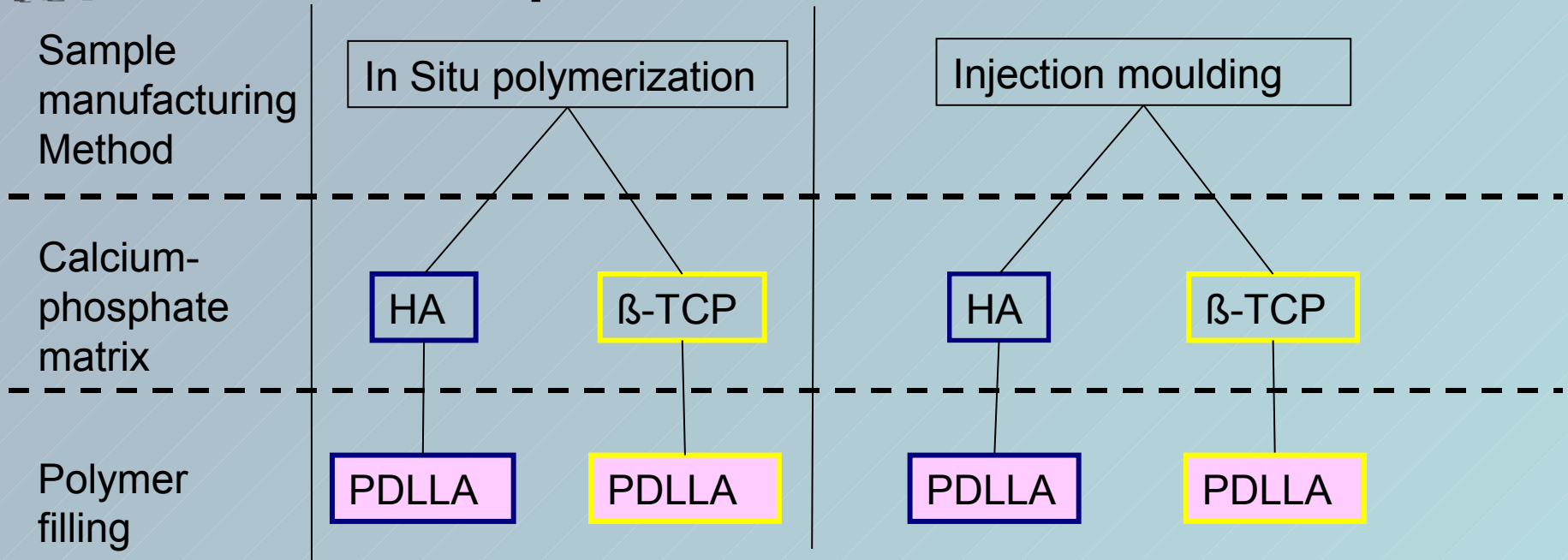

☺ No major machines required

☹ Not for large scale production

☹ Low initial molecular weight

☺ Higher molecular weight

☺ Potential for large scale production

☹ Ceramic matrix damaged under pressure of injected polymer

# Project aims

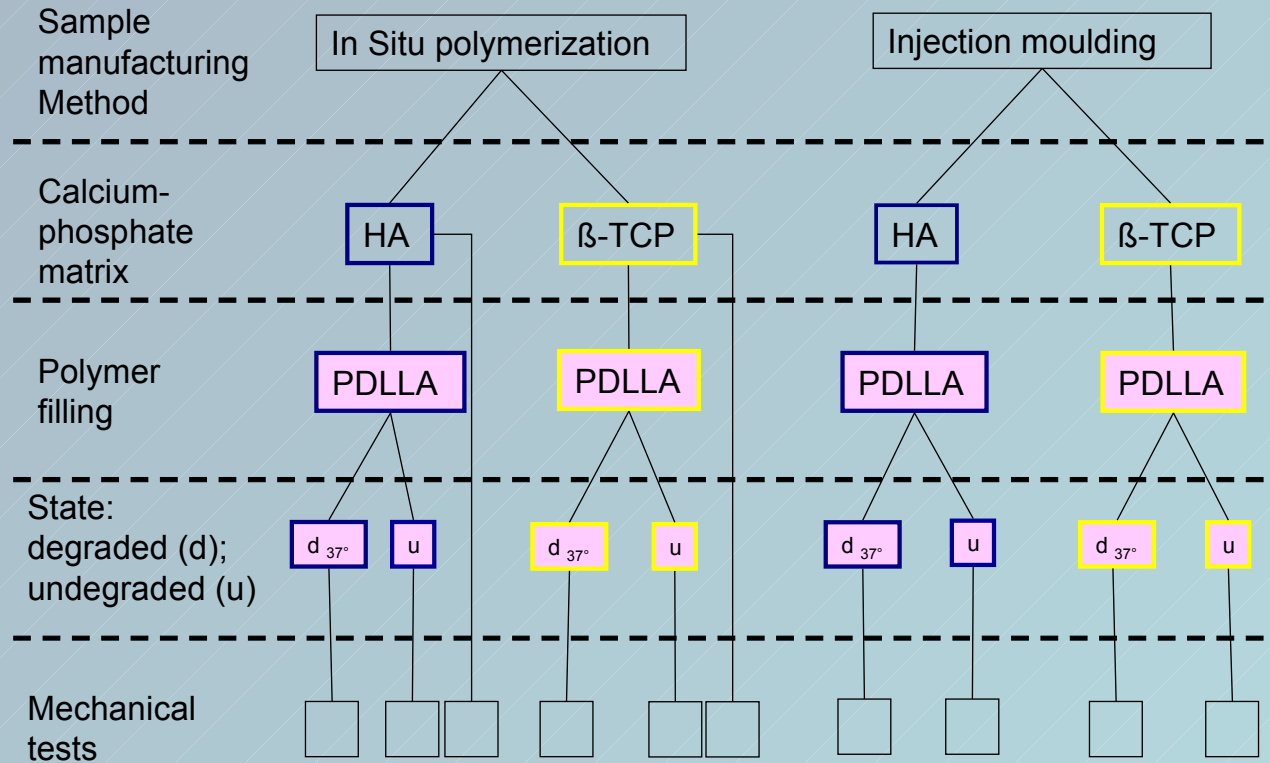

Find suitable polymer-ceramic-composites and characterize:

- Dissolution properties
- Mechanical properties

Depending on material and method of sample production

# Degradation study

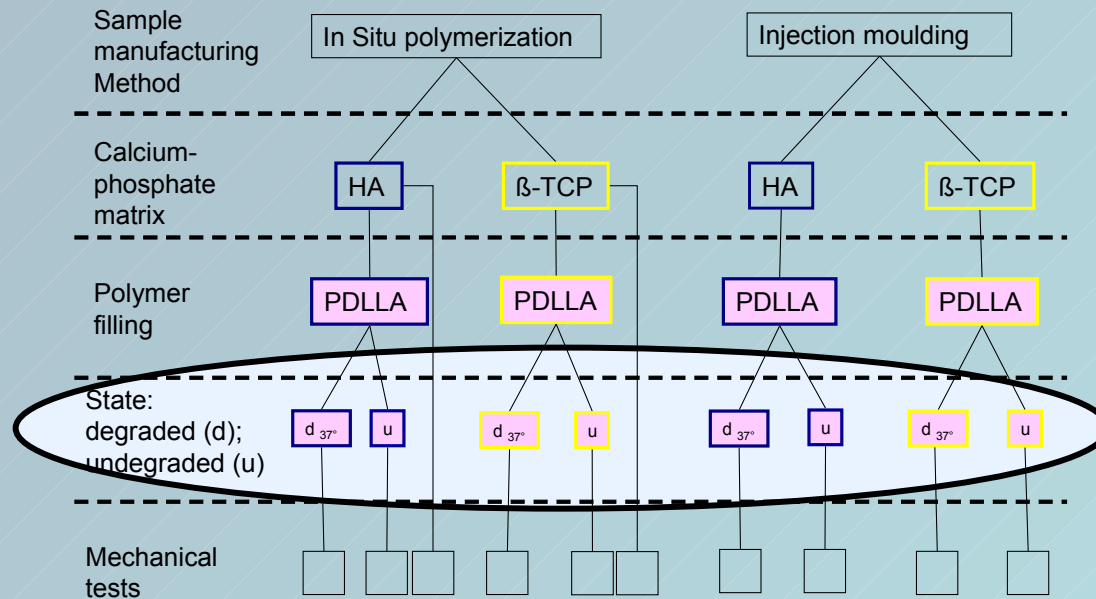

# Some basics on Polyester degradation

Homogeneous polyester sample

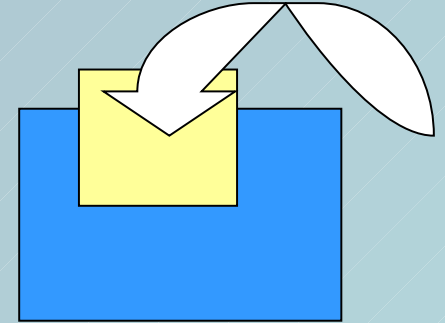

# Some basics on Polyester degradation

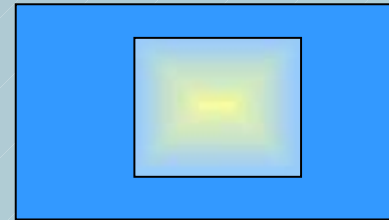
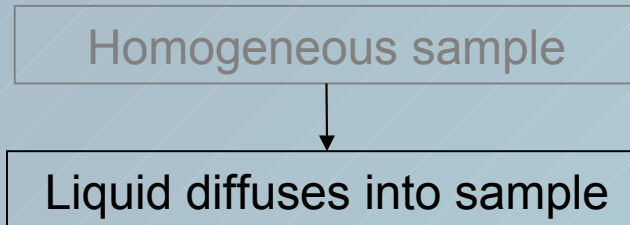

# Some basics on Polyester degradation

Homogeneous polyester sample

Liquid diffuses into sample.

Hydrolysis (scission of polymer chains)

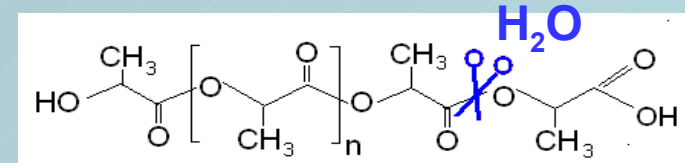

# Some basics on Polyester degradation

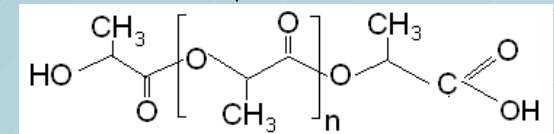
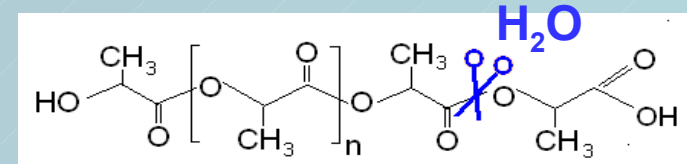
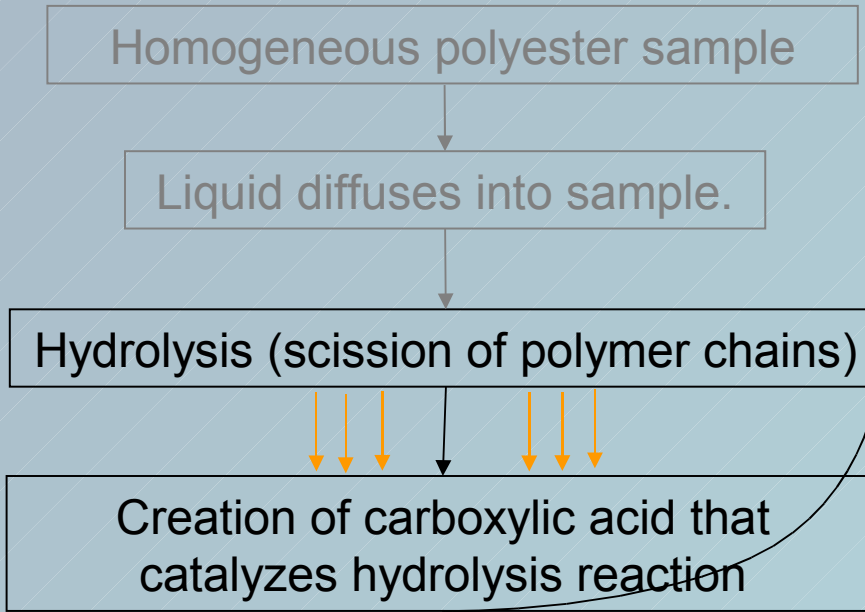

RCOOH (carboxylic acid)

# Some basics on Polyester degradation

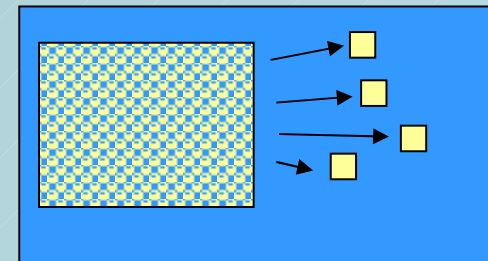
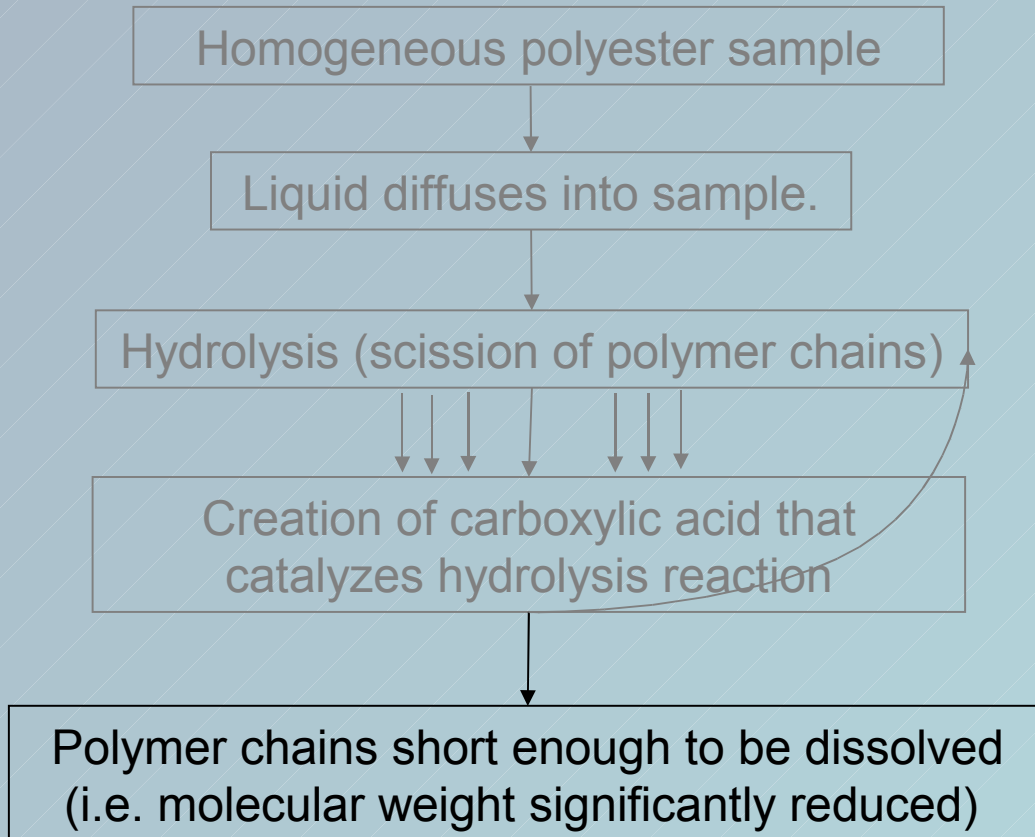

# Sample Characterization

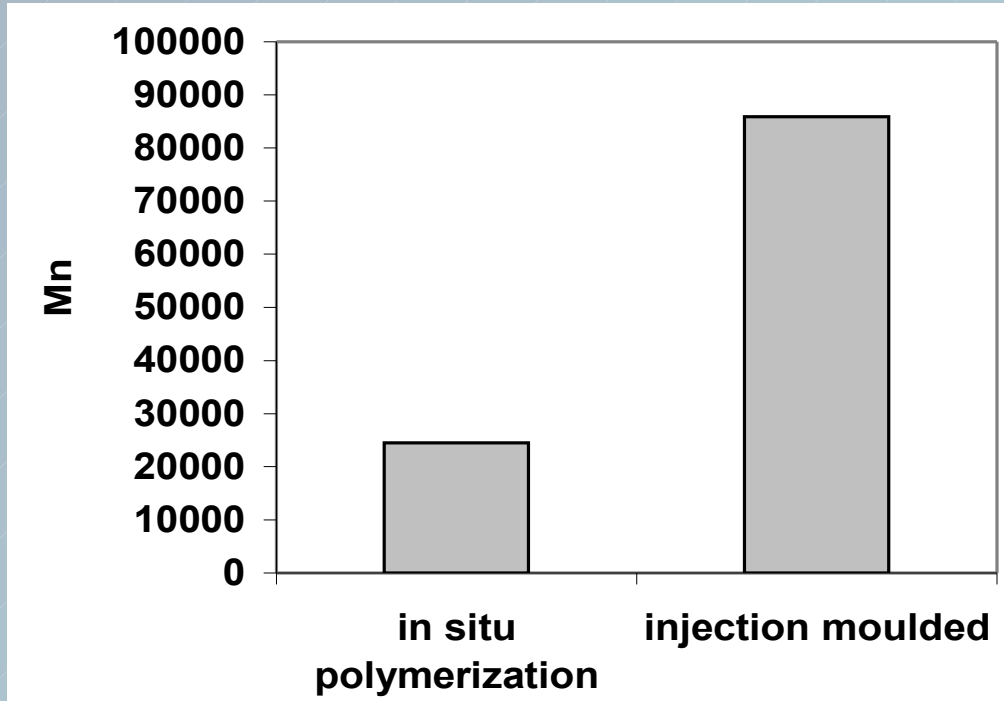

→ Faster degradation expected for in-situ polymerized samples

# Degradation study (I)

## Setup:

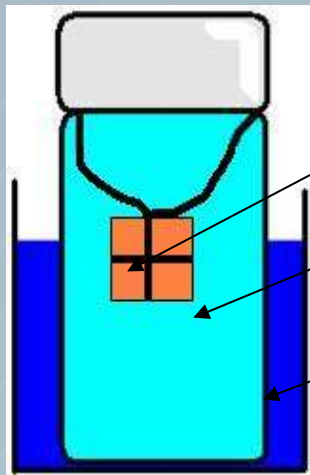

Sample\*

PBS, pH 7.4

Water bath, 37°C

## Measure:

- pH
- mass loss
- water absorption
- visual analysis with  $\mu$ CT  
(micro-computertomography)

\* $\beta$ -TCP matrix, filled with PDLLA (in situ polymerized)

# Degradation study (I)

Results after 49 days of degradation:

- Only 3% mass loss after 49 days
- No pH changes
- 50wt.% water absorption, sample swelling
- Observation of cracks in  $\beta$ -TCP matrix

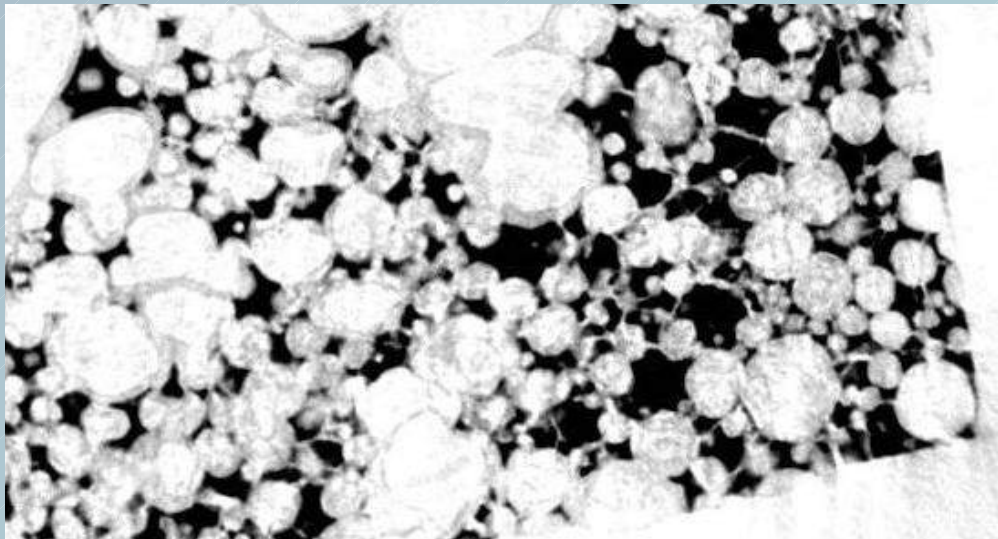
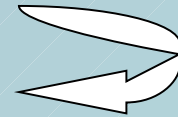

# Degradation study (I)

## Conclusions:

- Need to speed up experiment
  - Accelerate by increased temperature
- Optimize polymer-filling to reduce water absorption and minimize swelling
  - Poly(L)lactide + Lauric Acid:  
only 5wt.% water absorption reported\*

# Degradation study (II)

Accelerated degradation study of pure compression moulded PDLLA: Mass loss

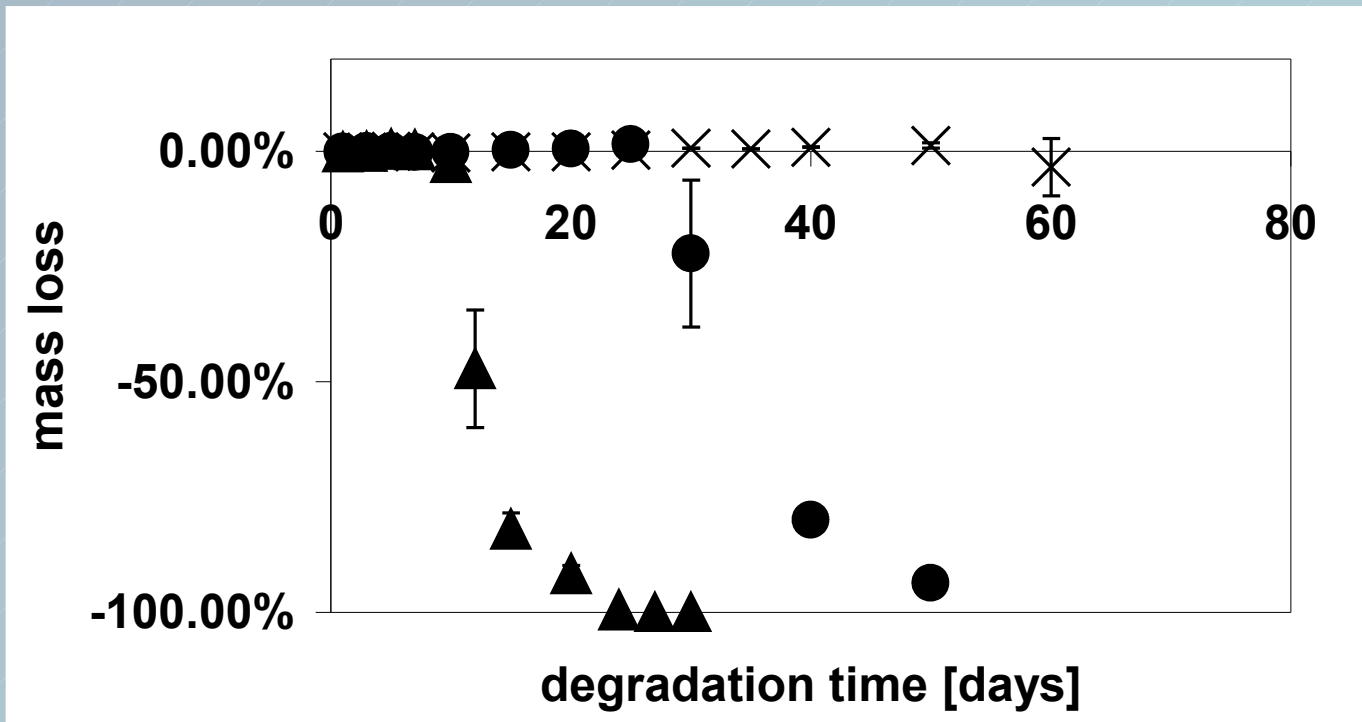

40°C ×  
45°C ●  
50°C ▲

Degradation of PDLLA accelerated as temperature increased



# Degradation study (II)

## Conclusions:

- Increased temperature leads to mass loss in much shorter time frames
- Next experiments to be conducted at 42°C

# Mechanical testing

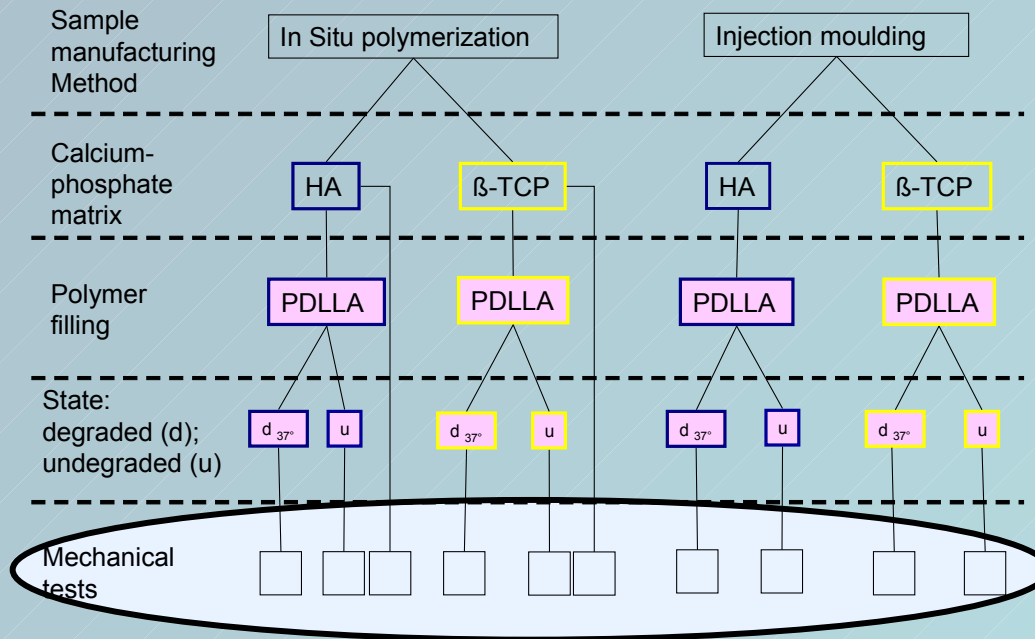

# Compression testing

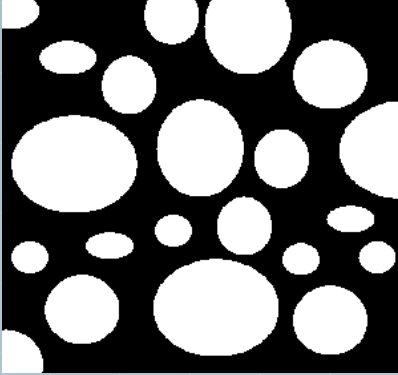
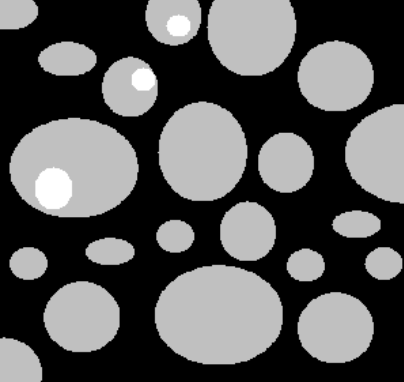
	Schematic	Stress-strain curve
<p>Porous Tricalcium- Phosphate Matrix (TCP)</p> <p>pore size: 500<math>\mu</math>m porosity: 82%</p>		
<p>Porous Matrix filled with Polymer (Poly (D,L) lactide)</p>		

# Compression testing

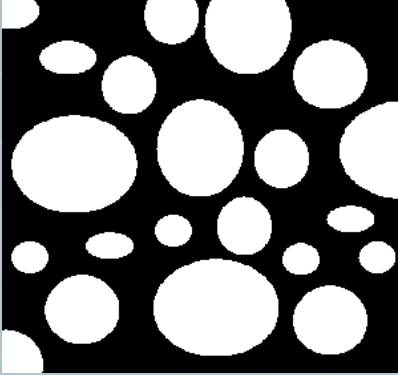
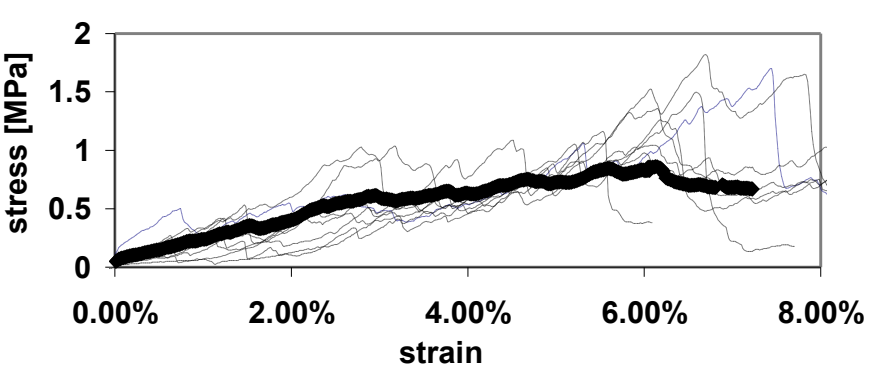
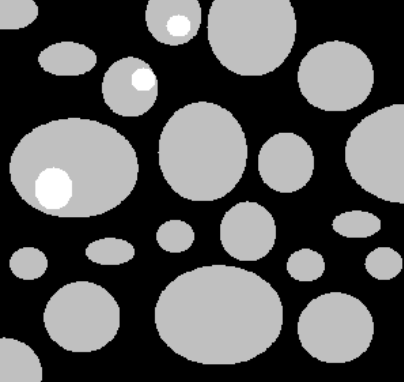
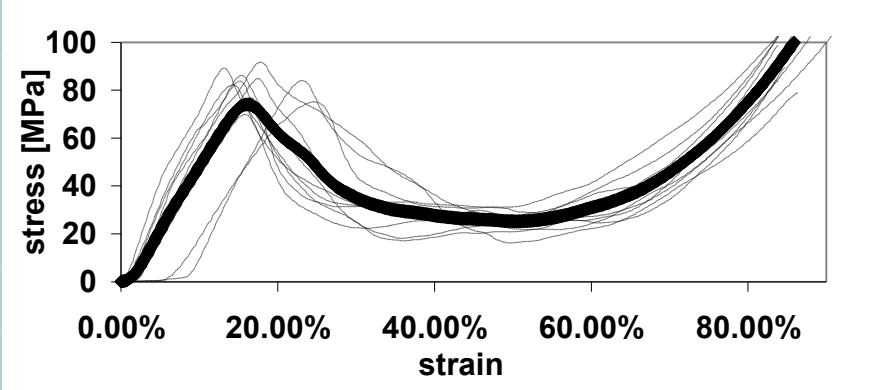
	Schematic	Stress-strain curve
<p>Porous Tricalcium- Phosphate Matrix (TCP)</p> <p>pore size: 500<math>\mu</math>m porosity: 82%</p>		
<p>Porous Matrix filled with Polymer (Poly (D,L) lactide)</p>		

**Mechanical behaviour changed from brittle to elastic-plastic**

# Compression testing

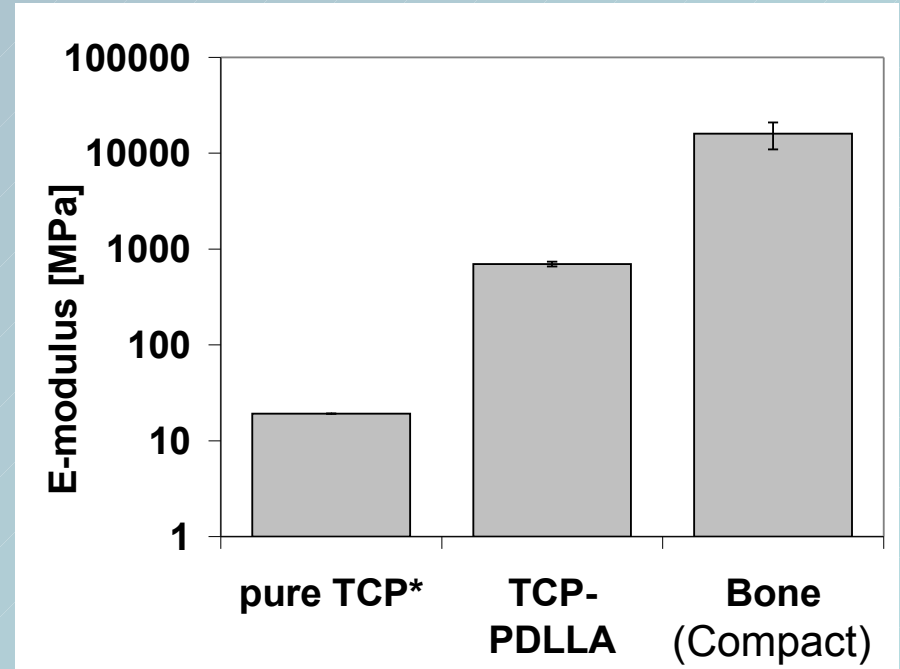
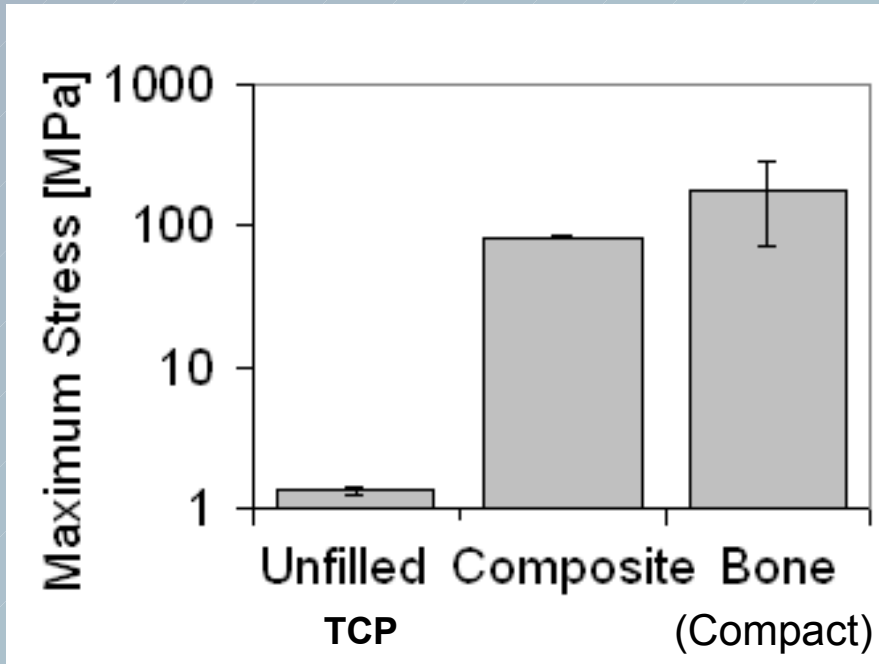

→ Polymer filling significantly increased compressive strength and E-modulus of  $\beta$ -TCP matrix

pure  $\beta$ -TCP (n= 14),  $\beta$ -TCP-PDLLA (n= 10)

# Compression testing

## Combination of compression testing with $\mu$ CT

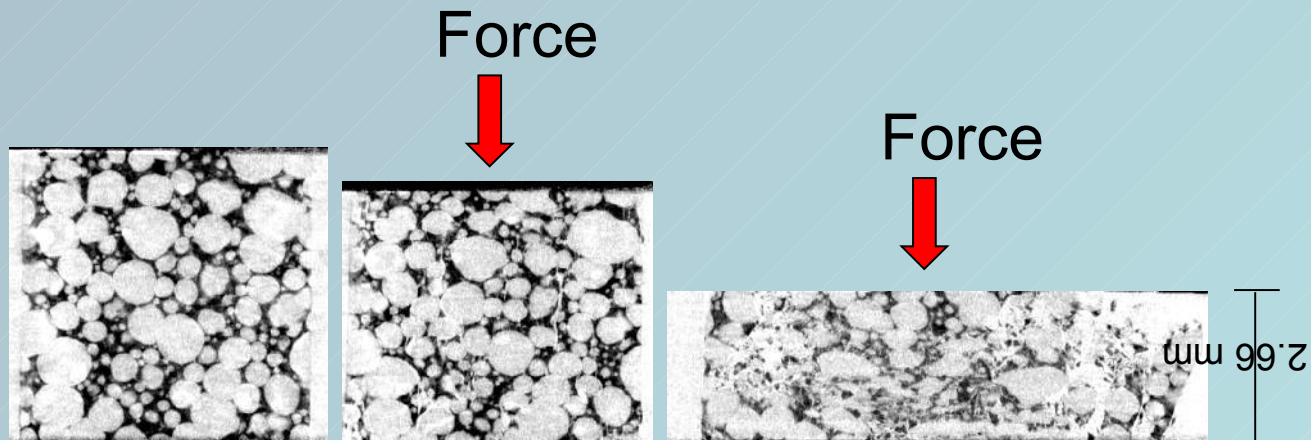

# Compression testing

## Combination of compression testing with $\mu$ CT

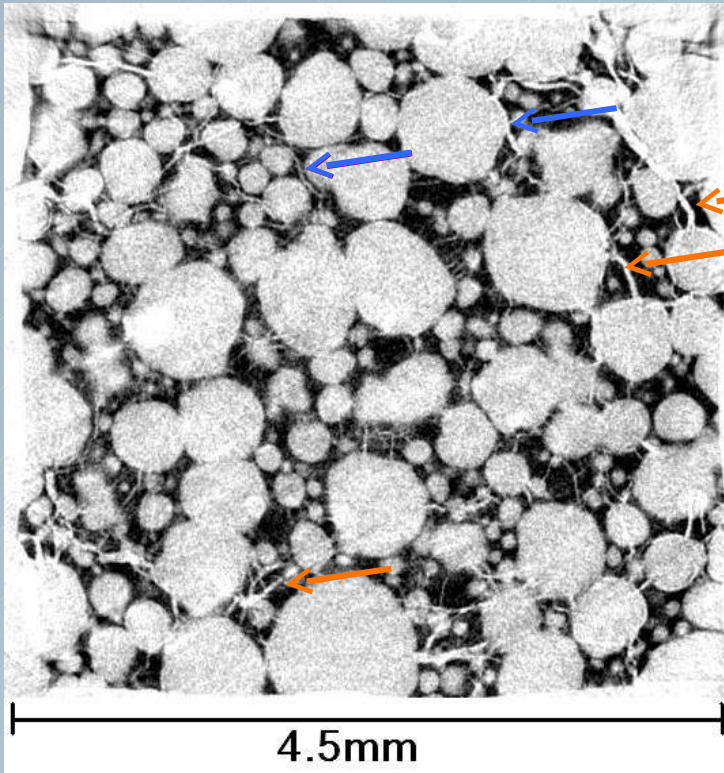

Sample compressed by 1mm

→ Failure of composite due to fracture of the ceramic struts

# Compression testing

## Combination of compression testing with $\mu$ CT

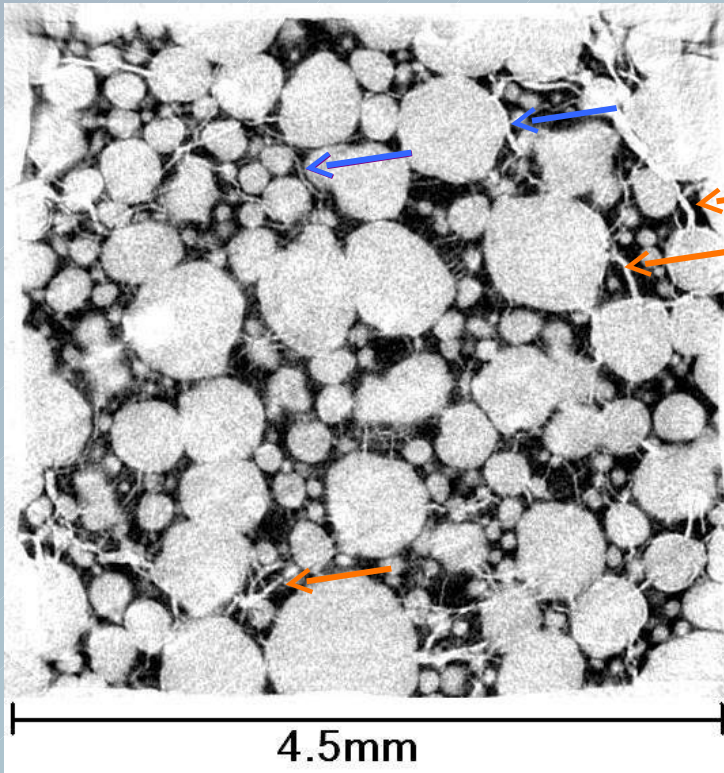

Sample compressed by 1mm

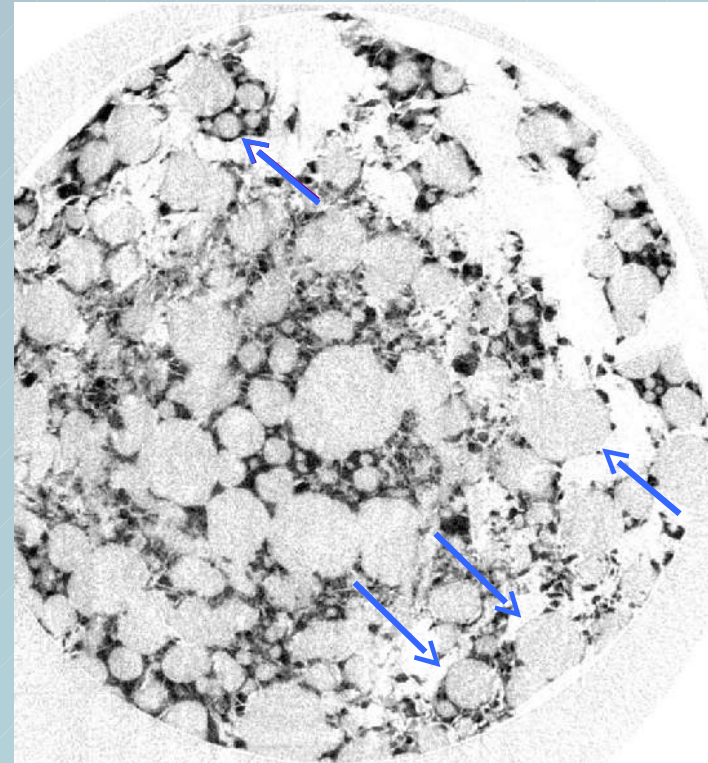

Sample compressed by 2.5mm

- Failure of composite due to fracture of the ceramic struts
- Stress deflection around the polymer phase results in debonding of polymer from ceramic along the crack lines

# Next experiments

# Next experiments

Sample  
manufacturing  
Method

In Situ polymerization

Injection moulding

Calcium-  
phosphate  
matrix

HA

$\beta$ -TCP

HA

$\beta$ -TCP

Polymer  
filling

PDLLA

PLA-la

...

...

...

...

...

...

# Next experiments

Sample manufacturing Method

In Situ polymerization

Injection moulding

Calcium-phosphate matrix

HA

$\beta$ -TCP

HA

$\beta$ -TCP

Polymer filling

PDLLA

PLA-la

...

...

...

...

...

...

State:

degraded (d);  
undegraded (u)

d<sub>42°</sub>

d<sub>37°</sub>

u

d<sub>42°</sub>

d<sub>37°</sub>

u

...

Mechanical tests

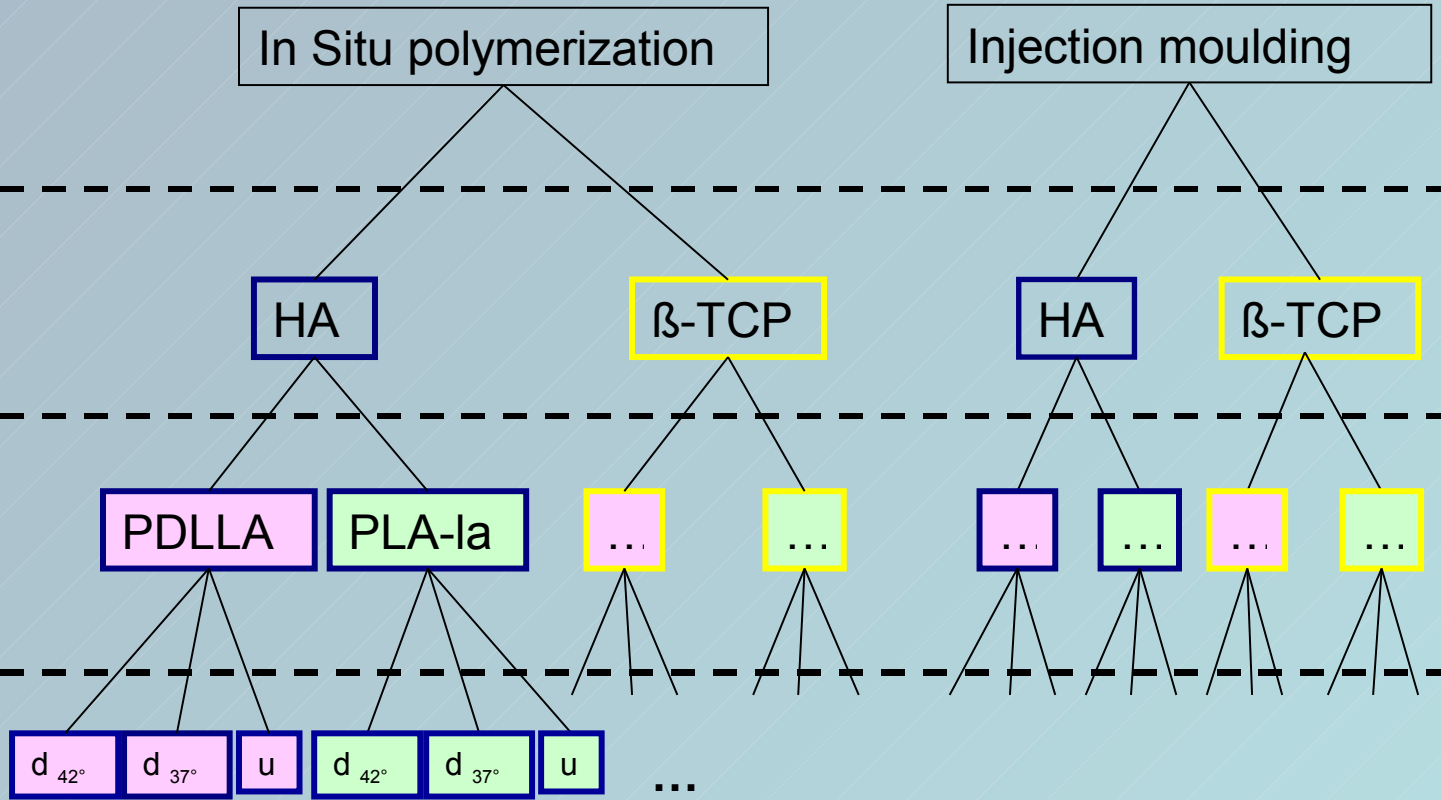

Thank you!

Ruth Cameron

David Farrar (Smith & Nephew)

David Morsley (Smith & Nephew)

Richard Hoskins (Smith & Nephew)

Mike Martyn (Bradford University)

CCMM group (Serena Best, Pete Laity, David Zou,  
Jacqui Capes, Xiaowei Fu, Alex Woesz, and the rest!)

# SONSTIGES

Look up degradation times for  
PDLLA films and sheets.

# Some basics on Polyester degradation

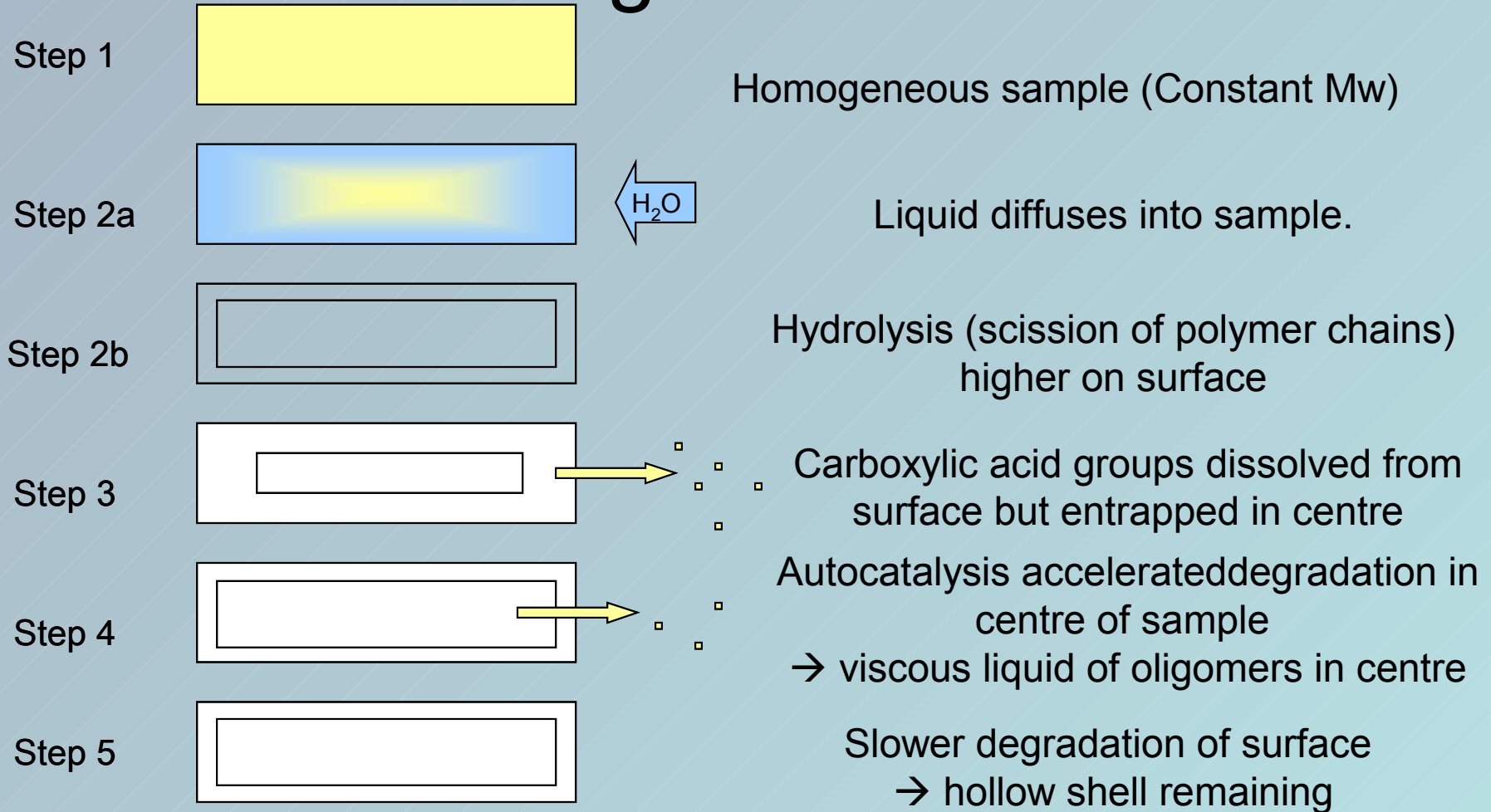

# Hydrolysis

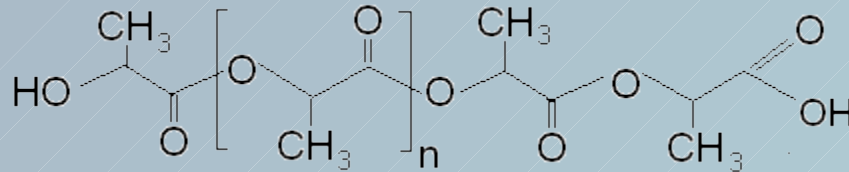

Polyester

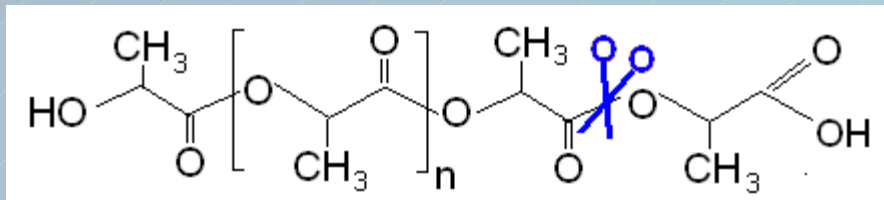
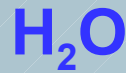

Hydrolytic scission on CO bond between alkyl group and oxygen

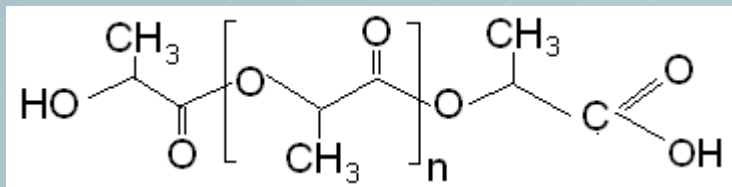

RCOOH

(carboxylic acid)

Catalyst

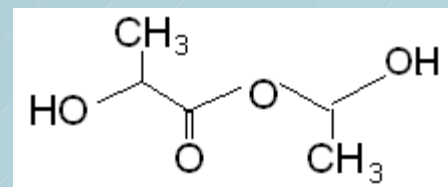

R'OH

## Bone Regeneration Principles

- **Tricalcium Phosphate**
- **Read about a prominent US clinician's experience with Cerasorb®**
- At the cellular level, bone consists of minerals, proteins, hormones, water, other molecules and three specialized bone cells: **Osteocytes**, which are bone cells within the bone's structure; **Osteoblasts**, that are bone-forming cells lining the surface and **Osteoclasts**, which are cells that resorb bone through physiologic degradation. Throughout life there is a highly regulated and balanced process keeping bone "fresh" by the interplay between osteoblasts building structure and osteoclasts resorbing it. This constant "remodelling" process can be affected by a number of factors like age (older bone remodels more slowly), running and exercise (which cause mechanical force to stimulate bone formation), smoking (which slows the process of bone formation) and the general health of the patient.
- The healing of bone defects is a complicated physiological process but in optimal conditions, injured bone can be reconstituted almost identically to its original shape. The healing process goes through three phases (inflammatory, reparative, and remodelling) with complete healing requiring three to six months for cancellous bone and four to eight months for cortical bone
- This figure depicts the main phases of bone defect healing in terms of their response intensity and time. Many fractures or voids take substantially longer to heal due to the patient's health or age and some do not heal at all when the defects are large. In large bone voids, a gap can form that is filled by fibrous tissue which prevents vascular penetration so no osteogenic cells can reach the area to complete the re-ossification process.
- Surgical intervention is required in these cases and the normal cellular process must be considered. Most cases also require the introduction of an augmentation material / bone substitute to encourage the biological bone regeneration process in the defect area. It is critical that the selected augmentation materials physiologically fit the phases of bone regeneration and not inhibit the regenerative processes in any way. Harvested autogenous bone is excellent for this purpose but often a second surgical procedure is difficult or the resulting material is insufficient to fill the void. Unlike older ceramic products, Cerasorb® with its pure phase  $\beta$  tricalcium phosphate composition, was designed to complement the physiological phases of bone regeneration. Initially, Cerasorb® provides a multi-porous matrix to encourage bone cell in-growth but then its resorption occurs uniformly, completely, and in parallel to the formation of endogenous bone. As the patient's bone forms, the granules of Cerasorb® resorb and yield "restitutio ad integrum" meaning to "restore to its original condition".
- With Cerasorb®, professionals can continuously monitor the entire regeneration process by X-ray because Curasan's  $\beta$  tricalcium phosphate is radio-opaque. However,  $\beta$ -TCP residuals on the X-ray film before implant



# The EVEN GREATER Need

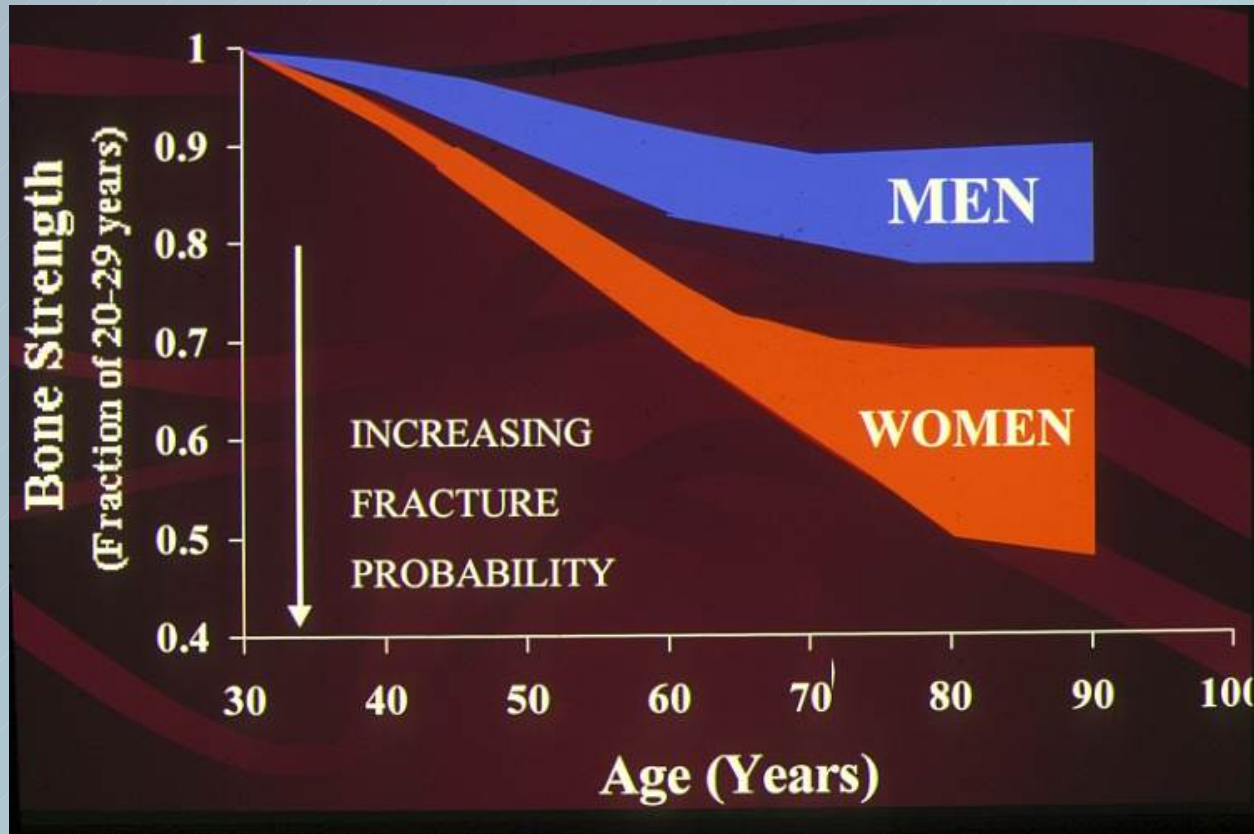

# Some basics on Polyester degradation

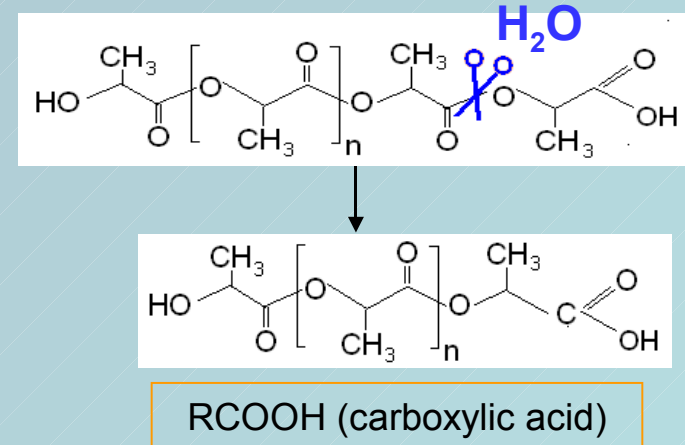
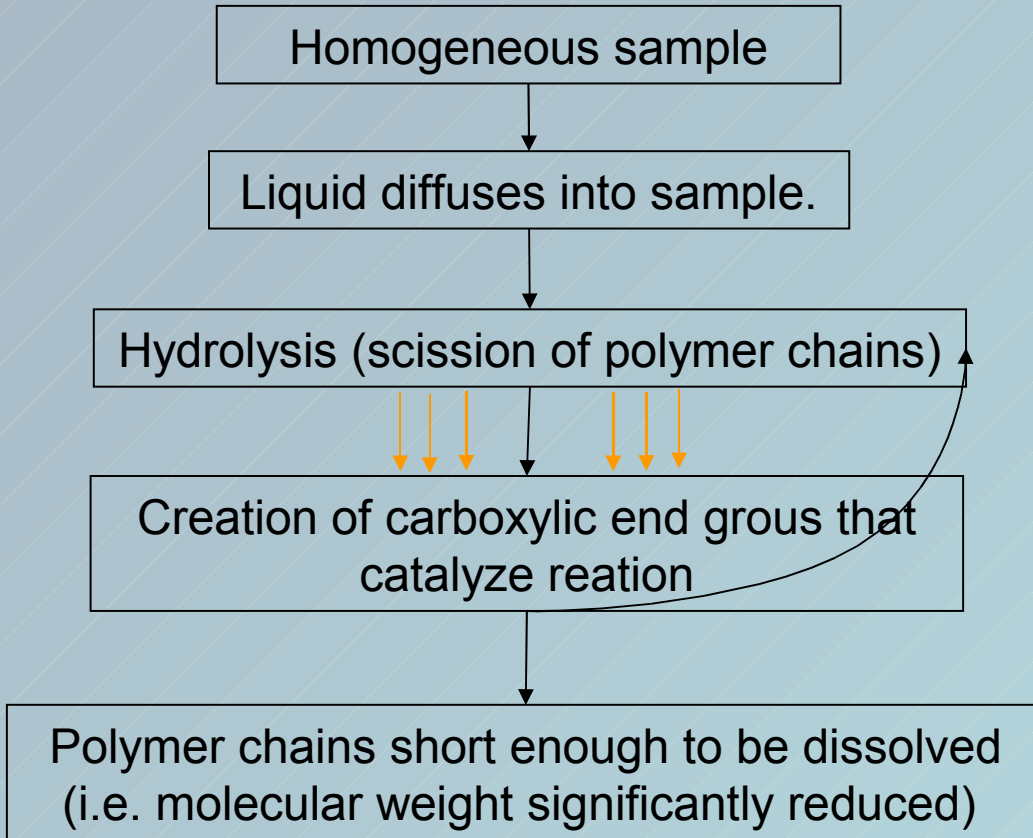



CCMM

Biomaterials for „Orthopedic applications“

# The Challenge: Osteoporosis

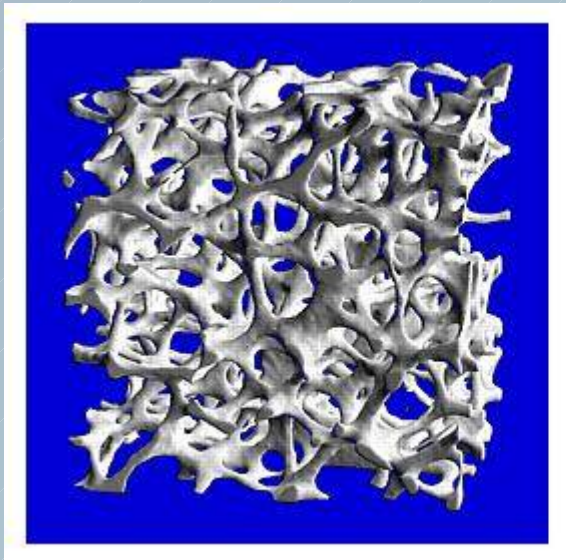

23 years

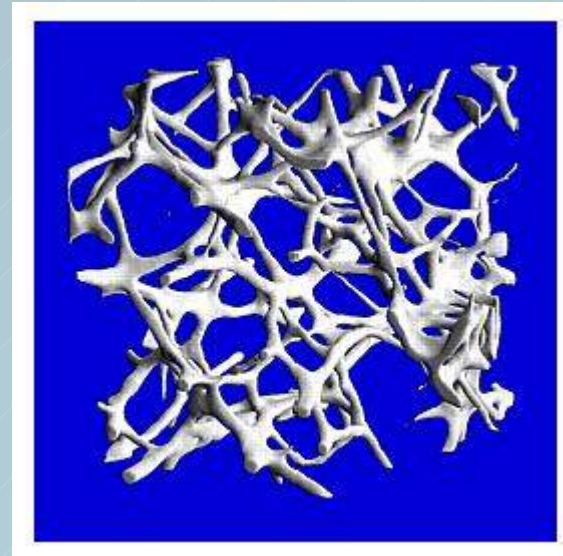

74 years

Affects 75 Mio. people in Europe, USA and Japan

# The EVEN GREATER Need

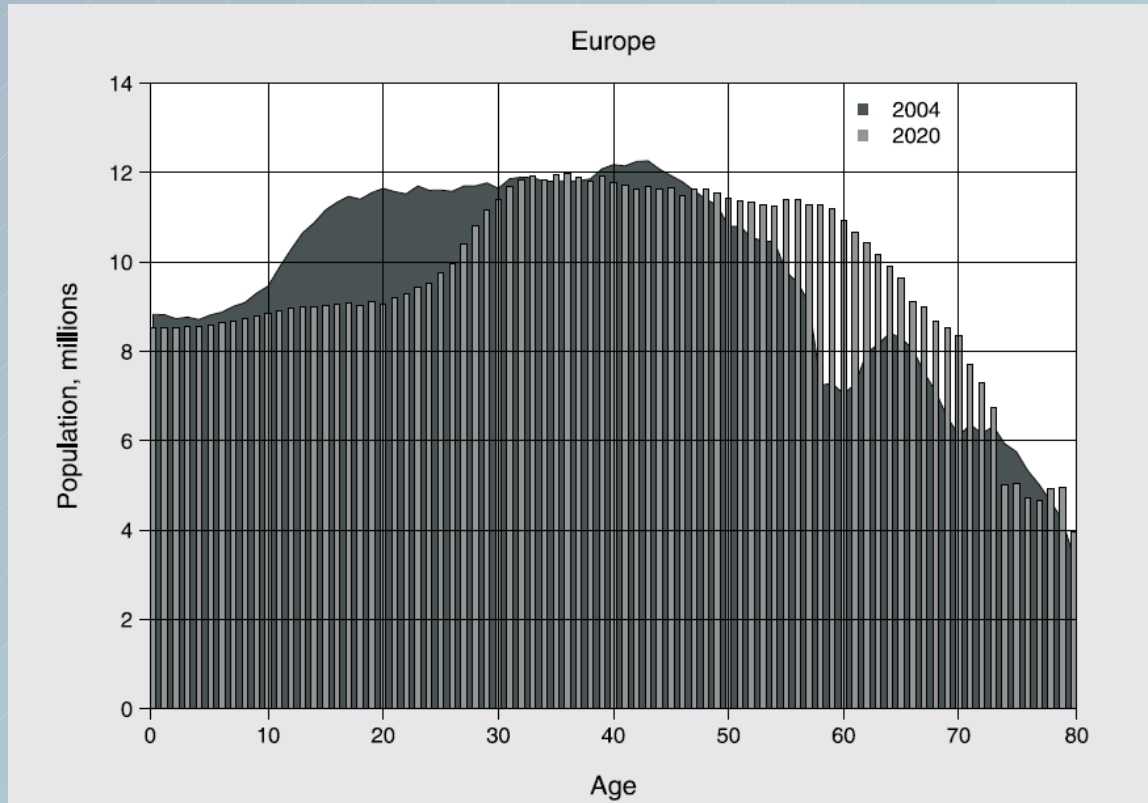

Cost for osteoporotic fractures double within next 50 years.

# Why hip implants fail

(15- 25% of all hip implants)

Friction between  
head and cup

Abrasion of  
polyethylene particles

Immune system attacks PE  
particles, but also surrounding  
bone



+Stress shielding

+Different stiffness of  
bone and implant

## Implant loosening

(60-70%: aseptic loosening!) (C. Mauffrey, A. Prasthofer: Hip Replacement, Changes In Trends: Are We Changing Our Practice For The Right Reasons?. *The Internet Journal of Orthopedic Surgery*. 2006. Volume 3 Number 2. )

# Experiments done

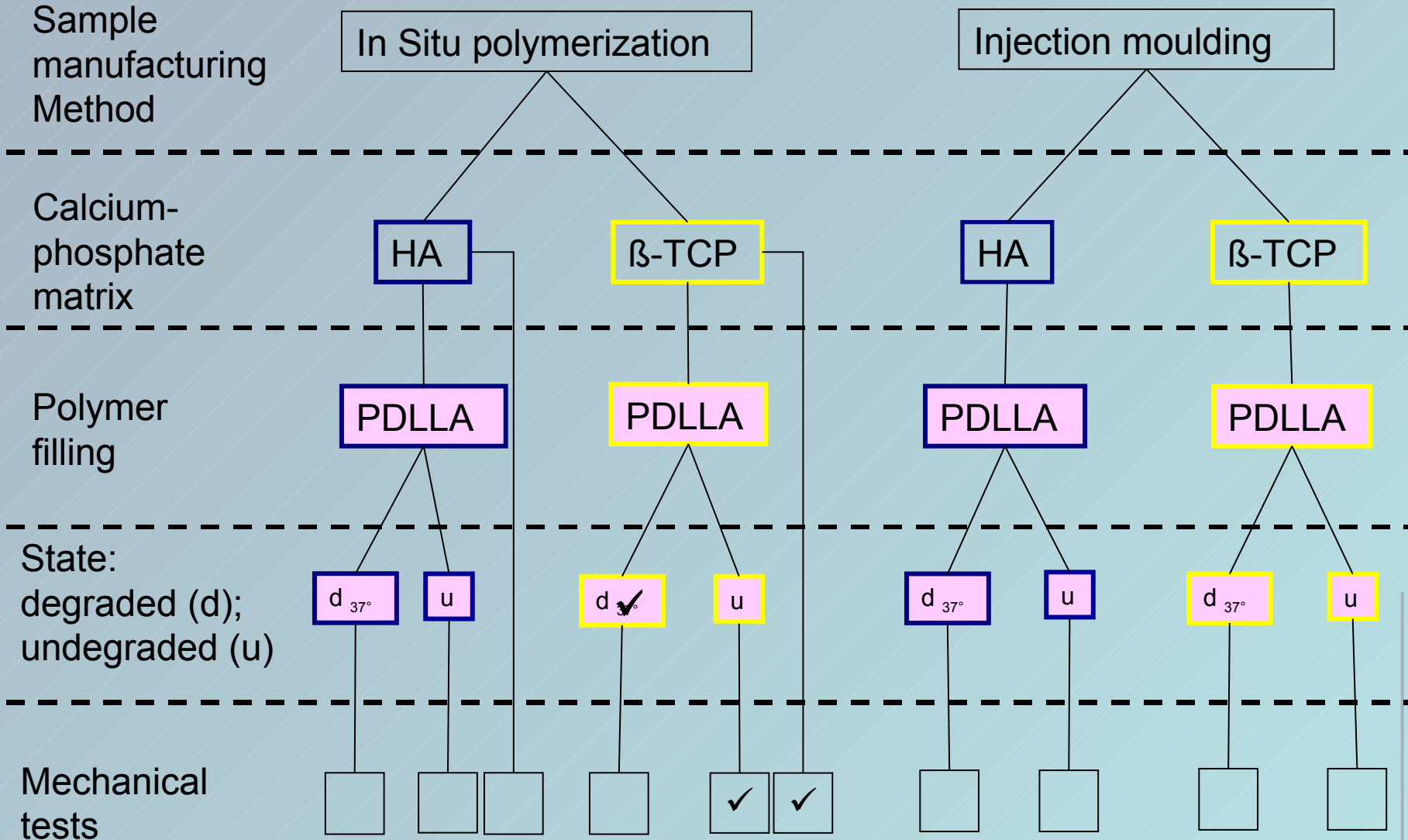

# Degradation study (II)

Accelerated degradation study of pure compression moulded PDLLA: Molecular weight

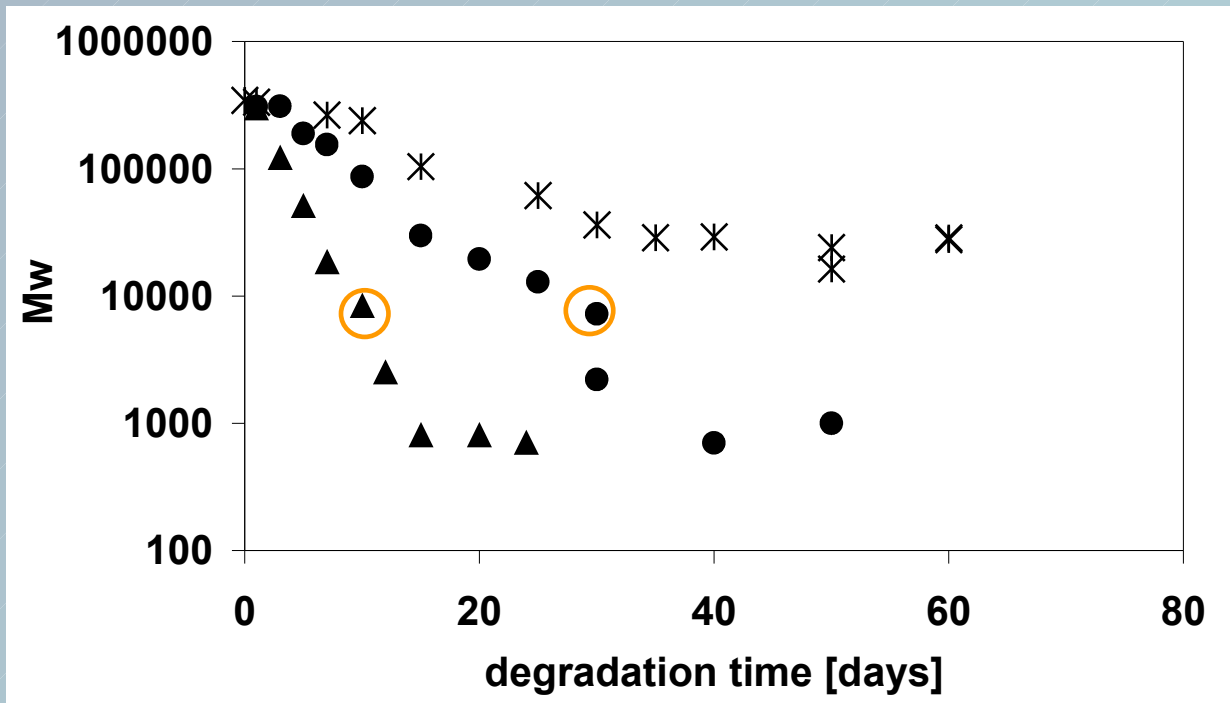

○ Onset of mass loss

40°C ×

45°C ●

50°C ▲

Mass loss was measured once molecular weight (Mw) was decreased below 10000

# Motivation for my project



- Hip replacements (UK): 35,000/yr (1 out of 1700 persons)
  - 15-25% of all hip-implants fail after 10-15 years
    - Wear debris
    - Stress shielding
    - Difference in stiffness
- } Implant loss

Motivation for my project

# Hip implant revision surgery

With removal of old implant valuable bone lost!

Where to fix the new implant???

Bone Grafts

Non-resorbable materials

Resorbable Materials that will be replaced by bone

- ☹️ Own bone:  
Second site of surgery
- ☹️ Donated bone:  
Immune reactions  
Spread diseases
- ☹️ Restricted availability

